

Specification of Roll Die

The following Die size is an example. Custom designed Die are available to order.

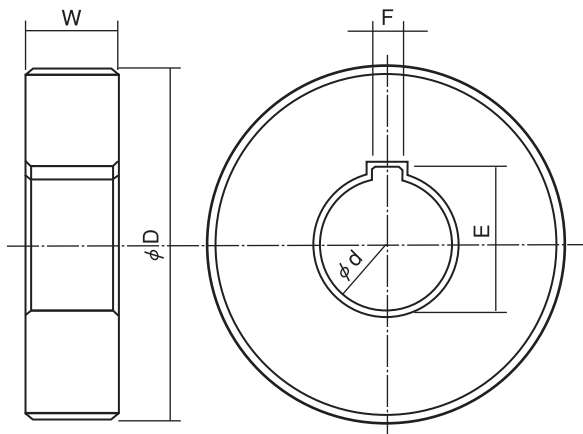

【 Specification 】

(Unit : mm)

Major Diameter	Hole Diameter (d)	Width (W)	Width of Key Way (F)	Depth of Key Way (E)
80~120	40	50MAX	6	43.5
120~220	54	100MAX	12	59

※Please ask our sales representative about additional specifications or special requests.

Our form rolling technology supports high quality mass production.

Pursuing superior accuracy of the form transfer.

Our original design fully maximises the forming area on the circumference of the Die, which produces very high-grade forming.

By holding the elongation, superior forming is maintained.

Designed for the most demanding applications and controls.

【 Note 】

- Work material may affect precision and life of the Die.
- When regrinding the Die, all tooth depth is removed and newly ground.

The number of regrinds can vary depending on the Die specifications. The life of the Die after grinding tends to be reduced compared to new Die.

UNION TOOL CO.
<http://www.uniontool.co.jp>

U.S. UNION TOOL, INC.
 UNION TOOL EUROPE S.A.
 TAIWAN UNION TOOL CORP.
 UNION TOOL (WAIGAOQIAO SHANGHAI) CO.,LTD.
 DONGGUAN UNION TOOL LTD.
 UNION TOOL HONG KONG LTD.
 UNION TOOL SINGAPORE PTE LTD.

